

SANDRA B. GLIŠIĆ  
DEJAN U. SKALA

Faculty of Technology and  
Metallurgy, University of Belgrade,  
Belgrade, Serbia

SCIENTIFIC PAPER

## DESIGN AND OPTIMISATION OF PURIFICATION PROCEDURE FOR BIODIESEL WASHING\*

*Almost complete methanolysis of triglycerides is usually not enough to fulfil the strict standards of biodiesel quality. A key step in this process is neutralization of alkali (catalyst) followed by the washing procedure necessary for removing different impurities such as traces of catalyst and methanol and removal of soaps and glycerol from esters phase. The washing with hot water is still widely used in many industrial units for the biodiesel production.*

*In this study, different procedures of biodiesel washing using hot water were investigated. The orto-phosphoric acid was suggested as the best compound for alkali catalyst (sodium hydroxide) neutralization. The main goal of the performed analysis was to minimize the water usage in the washing-neutralization step during the biodiesel production. Such solution would make the process of biodiesel synthesis more economical taking into account the decrease of energy consumed for evaporation of water during the final product purification, as well as more acceptable procedure related to the impact on environment (minimal waste water release).*

*Results of the performed simulation of the washing process supported by original experimental data suggested that neutralization after the optimized washing process of the methyl ester layer could be the best solution. The proposed washing procedure significantly decreases the amount of waste water giving at the same time the desired purity of final products (biodiesel and glycerol). The simulation of the process was performed using ASPEN plus software supported by ELCANTREL and UNIQUAC procedure of required properties calculation.*

*Key words: Biodiesel; washing of biodiesel; process intensification; catalyst neutralization.*

Alcoholysis of triglycerides using sodium or potassium hydroxide as a catalyst at 60 °C (if methanol is used), under the atmospheric pressure and a 6:1 molar ratio of methanol to triglycerides (two times higher compared to stoichiometry), has been carried out in the industry for decades [1-5]. Such working conditions were generally applied for the kinetics analysis of the so called "quasi-homogeneous" alkali catalyzed reaction. It was observed that approximately 90 min is the necessary reaction time in the batch process for achieving 90-98% conversion of triglycerides. After the reaction step, different separation and

purification techniques are required in order to separate fatty acid methyl esters (FAME) from glycerol and other by-products. Typically, the use of hot water washing can result in high purity (99%) and high yield of the biodiesel product (86%) [6]. However, the neutralization of alkali and the purification step performed using a larger amount of water create additional wastewater which are the weak points of such process. Furthermore, the removal of water from the reaction mixture leads to higher energy consumption. Downstream from the reactor, the recovery of the excess of methanol, the purification of methyl esters from the catalyst and the separation of glycerol as a co-product are usually needed. In the case when a raw material (vegetable oil or used vegetable oil) contains an appreciable amount of free fatty acids (FFA; several weight percents), the catalyst is also consumed due to the neutralization of acids causing decrease of the reaction rate of alcoholysis as a consequence of a decreased catalyst concentration. The

Corresponding author: S.B. Glišić, Faculty of Technology and Metallurgy, University of Belgrade, Karnegijeva 4, P.O. Box 3503, 11120 Belgrade, Serbia.

E-mail: sglisic@tmf.bg.ac.yu

\*Some part of this study was presented at 2<sup>nd</sup> International Congress on Green Process Engineering, Venice, Italy, 14-17 June 2009.

Paper received: 27 May, 2009

Paper revised: 03 July, 2009

Paper accepted: 14 July, 2009

presence of water in the feed (vegetable oil) is also undesired as it reduces the catalyst efficiency. The process flow diagrams for the production of FAME using a homogeneous alkali catalyst was proposed and analysed in different recently published papers [7-11].

Nowadays, two alternative commercial processes are being promoted, one using ion exchange resin and the other using magnesium silicate (Magnesol®). Both processes have the advantage of being waterless thus eliminating many of the problems outlined above but, other than some fairly sketchy advertising material little is really known about their performance. Recently published results [12] showed that the ion exchange resins do not have any effect on the various glycerides but have little effect on methanol after the first few hours of operation which can cause some of back washing of methanol towards the end of the cycle. Also, a slight increase in acid value as the products pass through the ion exchange column was detected and the fact that soap is absorbed may indicate a limitation for high soap containing feeds.

The production of biodiesel with full compliance with EN 14214:2003 or ASTM 6751-07 is a very challenging task. To meet both standards, biodiesel needs to be 99.7% FAME [13]. Unconverted triglycerides, diglycerides, monoglycerides, as well as glycerol, water and other undesired components, could cause a significant engine damage and loss of power. Therefore, high conversion and purification steps are most important for biodiesel production [14].

The main goal of this study is the analysis and design of the best route of the purification procedure for biodiesel washing with the aim to reduce the energy consumption and to reduce the amount of mineral acid used for neutralization. Such analysis was focused on the problem of the energy consumption as well as on the environmental aspect.

## EXPERIMENTAL METHODS

### Experimental synthesis and purification

#### Materials

Refined and edible sunflower oil (Dijamant, Zrenjanin, Serbia) was used. The acid, saponification and iodine values of the oil were 0.202 mg KOH/g, 195 mg KOH/g and 130 g I<sub>2</sub>/100 g, respectively, determined according to the AOCS official methods [15]. Certified methanol of 99.8% purity was purchased from Fluka (Switzerland). NaOH pellets purity of 85% was purchased from Merck-Alkaloid (Skopje, FYR of Macedonia). The water content in the used vegetable

oil and NaOH pellets were 0.20 mass% and 1.41 mass%, respectively, determined by Karl Fisher titration.

#### Reaction conditions and a purification procedure

The 6:1 molar ratio of methanol to sunflower oil was mixed in the 1-L glass reactor equipped with a two flat-blade paddle agitator. NaOH (1.0 g per 100 g of oil) was dissolved into methanol before use. The experiments were carried out at about 65 °C and atmospheric pressure during 2 h. The mixing of the reaction mixture was applied to produce a uniform dispersion of methanol and oil.

After a completed reaction, the reaction mixture was cooled down to room temperature. The unreacted methanol was evaporated using vacuum evaporator ((Heidolph Laborata 4001) at 35 °C and the absolute pressure of 250 mbar. The purification steps of FAME and a glycerol layer depend on the used procedure (classical used in industry, and, an optimized one performed in this study) and it was shown in Figure 1.

#### Composition of the reaction mixture

The chemical composition of the samples of the reaction mixture was analyzed using gas chromatography (Varian 3400) with a FID detector, an on-column injector and a fused silica capillary column (5 m×0.53 mm, film thickness 0.5 μm). The conversion degree of TG was calculated from the content of TG in the FAME/oil fraction of the reaction mixture, TG (in %), by the following equation:

$$X_{TG} = 1 - (TG/100)$$

The water content in the samples, before and after the washing procedure, was analysed using volumetric Karl Fisher titration (Karl Fisher titrator, Mettler DL18, Germany). The amount of the catalyst in different streams was determined using 0.1 N solution of HCl with phenolphthalein as an indicator.

#### Process simulation

The process simulation software ASPEN Plus® v2006 (developed by Aspen Technology Inc., Cambridge, MA, USA) was used to carry out the analysis of mass and energy balances for different purification steps.

The main process units of homogeneous alkali catalyzed alcoholysis (HACA) include: a chemical reactor, distillation columns, heat exchangers, pumps, a gravity separator and a column for FAME washing. The biodiesel production and simulation using the HACA was described and analyzed in previously published paper [16]. The plant capacity was set at production of 10000 tones FAME/year with 330 operating

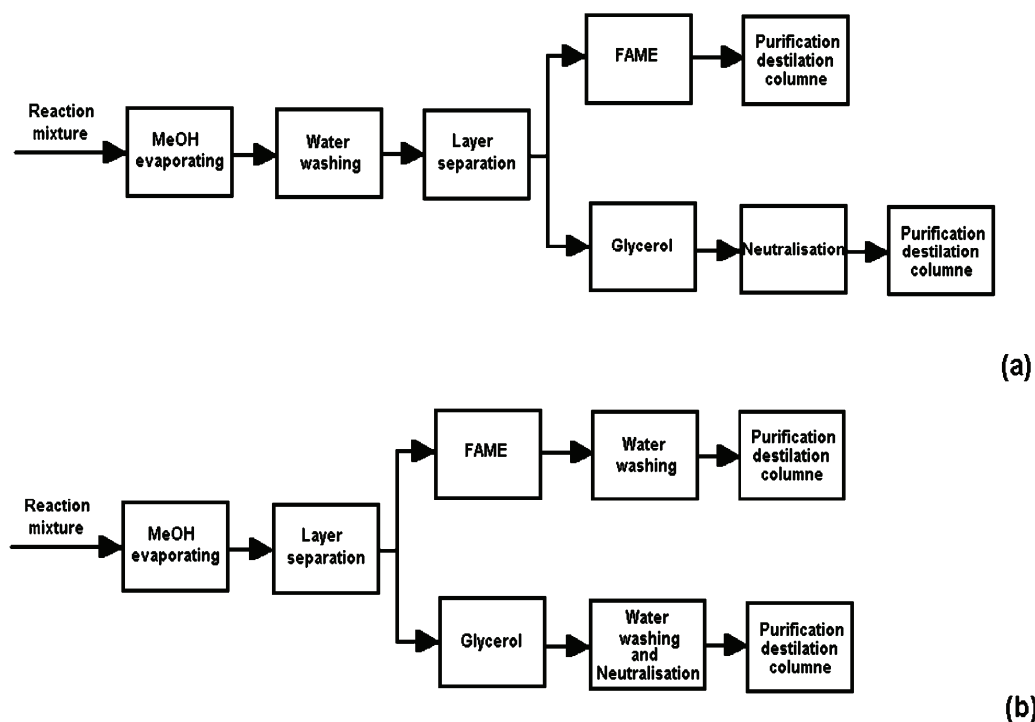

Figure 1. The separation and purification procedure for a simple (classical) procedure used in industry (a) and an optimized procedure (b).

days per year. The feed stream in this work represents the reaction mixture obtained after the reaction step and methanol recovery (the distillation of the unreacted methanol from the reaction mixture) signed as stream 203 [16].

The reaction of methanolysis of triglycerides was analyzed in the same way for both of the cases, the one-step and multi-step washing of the products of methanolysis. Methanolysis of triglycerides was realized at 60 °C and 0.4 MPa, using methanol to oil molar ratio of 6:1 and 0.8 mass% of catalyst based on oil. The reaction time in a reactor for FAME synthesis was 1.8 h when 95% conversion of triglycerides was obtained. Different amounts of water necessary for washing and the amount of  $H_3PO_4$  for one-step and multi-step washing of raw products, used in simulation, are given in Table 1.

Table 1. The process parameter for a different procedure of washing analyzed in this study

Process parameter	Simple (classical) washing procedure	Optimized washing procedure
Water for washing, kg/hr (70 °C)	210	55
Mass of $H_3PO_4$ , kg/h	8.3	2.4

The neutralization of the catalyst was simulated using the Electrolyte NRTL model (ELCANTREL, Appendix I), which is included into the ASPEN Plus® v2006 software. The UNIQUAC model (Appendix II) was used simulating the liquid-liquid equilibria (LLE) to obtain the triangle diagram and as a general thermodynamic model for all processes in the simulations.

## RESULTS AND DISCUSSIONS

### The simple washing procedure - usually applied in industrial plants

The removal of the catalyst is necessary in the alkali catalyzed process which is realized using a washing column. The process flowsheet of a simple washing procedure was presented in Figure 2. According to the simulations performed in this study a flow of 200 kg/h of water is required in order to remove all the catalyst from FAME present in a stream 302-A. The stream 302-A is composed of glycerol, water, small amounts of methanol and NaOH which should be neutralized in a further stage of the process by adding a necessary amount of mineral acid ( $H_3PO_4$ ). This stage of the process was carried out in the reactor R-401. The resulting stream is a mixture of water, glycerol and insoluble  $Na_3PO_4$ . To separate the

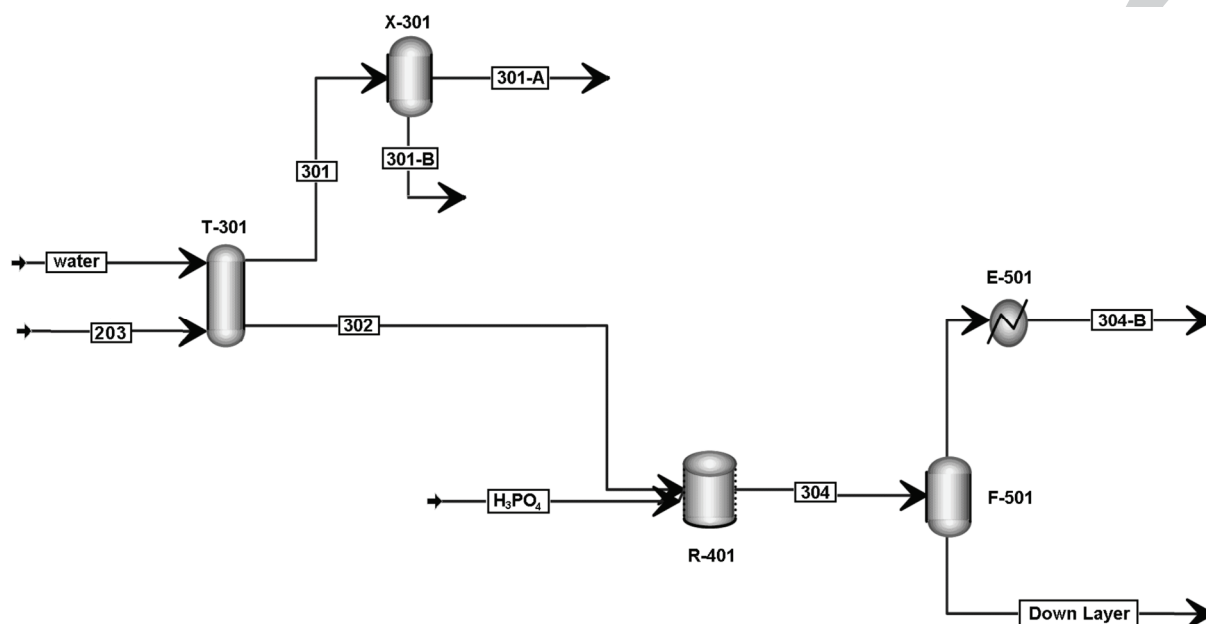

Figure 2. Simple (classical) procedure of biodiesel washing and catalyst neutralization.

salt from water and glycerol, a unit for precipitating the salt and to recover the glycerol and water which will be purified in a further stage of the process is required. This must be performed to recover glycerol as a valuable product of FAME synthesis.

The catalyst present in the stream 302-A (336.1 kg/h), is removed by neutralization with 8.304 kg/h of  $H_3PO_4$  (100% purity) (Table 2) and the formed salt is precipitated. The excess of water is necessary to eva-

porate and for that reason, after the neutralization step, the stream 304 (outlet from reactor R-401) was fed into a flash unit (F-501). The stream 304B from the flash column unit F-501 contains glycerol, methanol and water which is heated up in a heat exchanger E-501 and fed into distillation column for the final glycerol purification. Precipitated salt is present as a bottom product of F-501.

Table 2. Mass balance of a simple procedure of biodiesel washing and catalyst neutralization

Stream	203	301	301-A	301-B	302	304	304-B	$H_3PO_4$	Down layer
	Mass, %								
Methanol	0.463	0.0024	0.0024	0.0536	2.0	1.9	1.97	0	0.0042
Glycerol	8.82	0	0	0	38.3	36.3	97.3	0	12.4
Triolein	4.84	5.33	5.34	0	0	0	0	0	0
FAME	85.2	94.0	94.0	-0	0.0009	0.0009	0.0009	0	0.0006
NaOH	0.717	0.274	0.274	0.509	2.03	0	0	0	0
Water	0	0.427	0.383	99.4	57.6	58.4	0.80	54.5	0.182
$H_3PO_4$	0	0	0	0	0	0	0	44.6	0
$NA_3PO_4$	0	0	0	0	0	0	0	0	0
$NA^+$	0	0	0	0	0	0.0006	0	0	0.0162
$H_3O^+$	0	0	0	0	0	0	0	0.147	0
$H_2PO_4^-$	0	0	0	0	0	-0	0	0.748	-0
$OH^-$	0	0	0	0	0	0	0	0	0
$HPO_4^{2-}$	0	0	0	0	0	-0	0	-0	-0
$PO_4^{3-}$	0	0	0	0	0	0	0	0	0
Monosodium phosphate	0	0	0	0	0	0	0	0	0
Disodium phosphate	0	0	0	0	0	3.42	0	0	87.4
Total Flow, kg/h	1458.4	1321.9	1321.3	0.5828	335.6	354.4	340.06	18.304	13.856
Temperature, °C	60	50	40	40	60	26.9	102.4	25	277.4

### The optimized washing procedure

The process flowsheet of the optimized washing procedure is presented in Figure 3. The feed stream (the same composition as stream 203; Fig. 3) was separated in a separator B1 into two layers, *i.e.*, a glycerol layer (stream 205) and a methyl ester layer (stream 204). The glycerol layer contains 18.9 mass% of total NaOH from the feed stream. The methyl ester layer was then mixed with 50 kg/h of hot water in a column T-301 and after that the water layer was separated (stream 302). Using such washing procedure

the 45.8% of the initial mass of NaOH in the stream could be removed (Streams 204 and 302; Table 3). After the washing and separation of the water and methyl ester layer, the stream 301 is sent to purification in a distillation column where the final FAME product is obtained according to the EN 14214 biodiesel standard.

The amount of 50 kg/h of hot water in the column T-301 necessary for FAME washing was obtained by a sensitivity analysis. The effect of the water consumption on NaOH content in the FAME layer

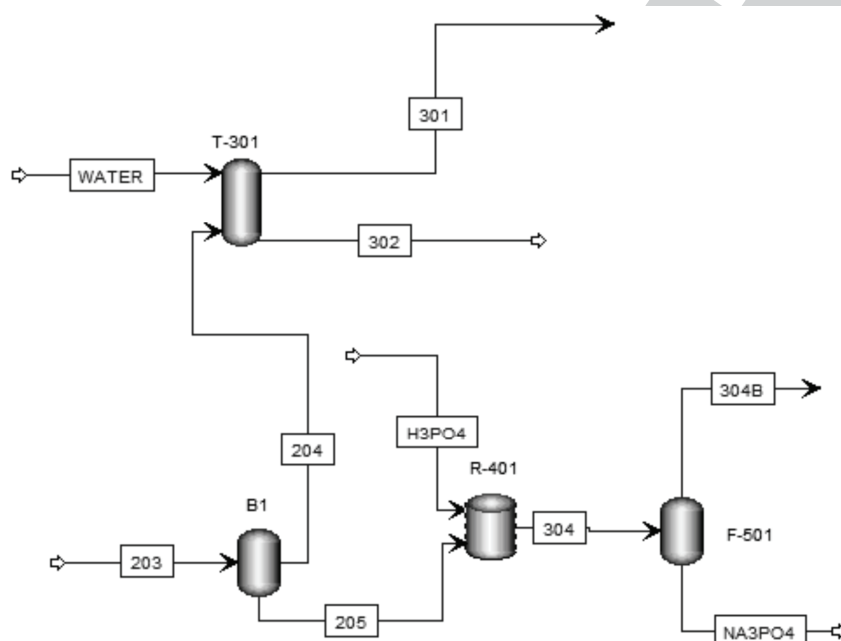

Figure 3. Optimized procedure of biodiesel washing and catalyst neutralization.

Table 3. Mass balance of the optimized procedure of biodiesel washing and catalyst neutralization

Stream	203	204	205	301	302	304	304B	H <sub>3</sub> PO <sub>4</sub>	NA <sub>3</sub> PO <sub>4</sub>
	Mass, %								
Methanol	0.463	0.30	0.977	0.086	5.096	3.489	3.800	0	0.021
Glycerol	8.82	0.048	94.659	0	1.144	89.816	91.885	0	66.736
Triolein	4.84	5.08	0	5.09	0	0	0	0	0
FAME	85.2	93.86	0.056	94.00	0	0.053	0.057	0	0.001
NaOH	0.717	0.703	2.59	0.334	1.615	0	0	0	0
Water	0	0	0	0.473	92.145	3.910	4.257	62.814	0.034
H <sub>3</sub> PO <sub>4</sub>	0	0	0	0	0	0.018	0	36.037	0.220
NA <sub>3</sub> PO <sub>4</sub>	0	0	0	0	0	0	0	0	0
NA <sup>+</sup>	0	0	0	0	0	0.002	0	0	0.029
H <sub>3</sub> O <sup>+</sup>	0	0	0	0	0	0	0	0.188	0.000
H <sub>2</sub> PO <sub>4</sub> <sup>-</sup>	0	0	0	0	0	0.010	0	0.961	0.124
OH <sup>-</sup>	0	0	0	0	0	0	0	0	0
HPO <sub>4</sub> <sup>-</sup>	0	0	0	0	0	0	0	0	0
PO <sub>4</sub> <sup>-</sup>	0	0	0	0	0	0	0	0	0
Monosodium phosphate	0	0	0	0	0	0	0	0	0
Disodium phosphate	0	0	0	0	0	2.701	0	0	32.835
Total Flow, kg/h	1270.77	1150.99	119.78	1154.65	48.33	124.13	113.92	6.35	10.21
Temperature, °C	60	70	70	50	60	135	272	25	272

was calculated and presented in Figure 4. The rate of washing defined as:

$$RW = 100 \times \frac{d(\Delta mass_{NaOH})}{d(\Delta mass_{water})}$$

was analyzed and it was found that the largest change of RW exists if 20 to 100 kg/h of water is used for FAME layer washing.

The glycerol layer (stream 205) was neutralized in the reactor R-401. The neutralization process requires the addition of the exact amount of orto-phosphoric acid necessary for precipitation of sodium dihydrogen phosphate from the solution (stream 304; Table 3). The separation of salt is achieved in the evaporator F-501; the glycerol layer is purified from the sodium hydroxide but also from the water and sodium dihydrogen phosphate (stream 304B).

The FAME layer (stream 301; Table 3) has almost the same purity as the methyl esters obtained in a previously described simple procedure of purification (stream 301-A, Table 2). However, the NaOH residue in FAME stream does not present a specific problem and could be easily separated in the final stage of FAME purification.

#### The comparison of the results obtained by simulation and experimentally determined

The results of different washing procedure were experimentally proved and the data measured are presented in Tables 4 and 5. The comparison of these results indicates a good agreement to the values calculated using specific thermodynamic models and Aspen plus software (Tables 2 and 3).

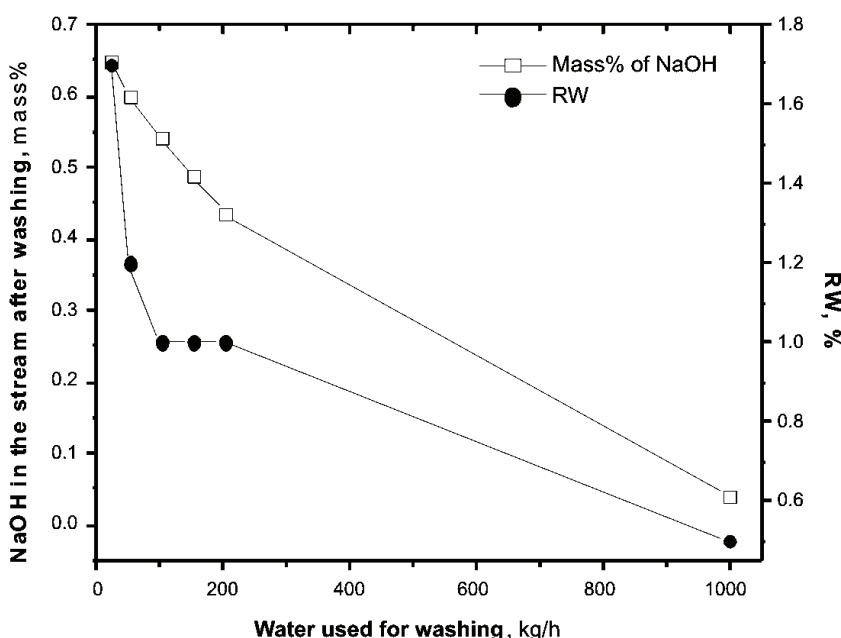

Figure 4. Relation between RW and the amount of water used for FAME washing.

Table 4. The experimental verification of data for a simple procedure of biodiesel washing

Stream	Reaction mixture	After methanol separation	FAME layer after washing	Glycerol layer after washing	Glycerol after neutralization
			Mass, %		
Methanol	12.29	1.56	0.50	3.49	5.79
Glycerol	7.47	7.67	0	23.22	38.59
Triolein	2.42	2.92	4.02	1.10	1.83
FAME	76.49	86.53	95.34	26.44	43.93
NaOH	1.33	1.32	0.14	3.93	0
Water	0	0	0.6	41.82	9.86
H <sub>3</sub> PO <sub>4</sub>	0	0	0	0	0
Mass, g	533.4	503.0	415.9	168.3	101.3
Temperature, °C	20	45	50	50	45

Table 5. The experimental data for the optimized procedure of biodiesel washing

Stream	Reaction mixture	After methanol separation	FAME layer	Glycerol layer	FAME after washing	Glycerol after neutralization
	Mass, %					
Methanol	12.29	1.46	0.50	4.91	0.50	4.69
Glycerol	7.57	7.56	0	42.30	0	40.39
Triolein	2.32	2.81	4.01	1.21	4.02	1.16
FAME	76.50	86.63	95.13	45.34	95.34	43.3
NaOH	1.33	1.32	0.36	6.24	0.14	0
Water	0	0	0	0	0.6	10.46
H <sub>3</sub> PO <sub>4</sub>	0	0	0	0	0	0
Mass, g	533.4	503.0	416.5	85.6	415.2	101.3
Temperature, °C	20	45	50	50	45	45

The amount of experimentally detected methanol in the reaction mixture after the separation of an excess of methanol and calculated by simulation is different (stream 203, Tables 2 and 3; and stream “after methanol separation” in Tables 4 and 5). The main reason is that only one theoretical plate is the real situation for distillation of the excess of methanol under an experimental condition thus resulting in a higher amount of methanol in a mixture containing mainly FAME and glycerol. However, the experimentally verified content for methanol (1.51 mass%), as well as the value calculated by simulation (0.47 mass%), do not have an influence on further purification steps of that mixture.

The distribution of NaOH between the glycerol and methyl ester layers is very important and depends on the amount of water and methanol present in both layers. The sodium hydroxide is soluble in water (111 g/100 cm<sup>3</sup> at 20 °C) and less soluble in the methanol (23.8 g/100 cm<sup>3</sup> at 20 °C). The triangular diagrams for the system FAME-water-NaOH (Fig. 5a)

and FAME-methanol-NaOH (Fig. 5b) show that almost complete miscibility of FAME, methanol and NaOH exist and that in the system FAME and NaOH the water will solve NaOH and it will be removed from the FAME layer.

Accordingly, the distribution of NaOH in the water and FAME layer after separation will be defined by water solubility in fatty acid methyl esters. Such conclusion is derived from the data given in Figs. 5 and 6. Namely, from both triangular diagrams it is clearly visible that the distribution of NaOH in such complex system and between two layers is defined by the amount of water used for washing.

The main conclusion which can be derived from the above analysis is that for complete removal of NaOH from the FAME layer the multi step repeated water washing must be applied. Namely, some equilibrium amount of water is always present in FAME layer in which even traces of NaOH could be easily dissolved.

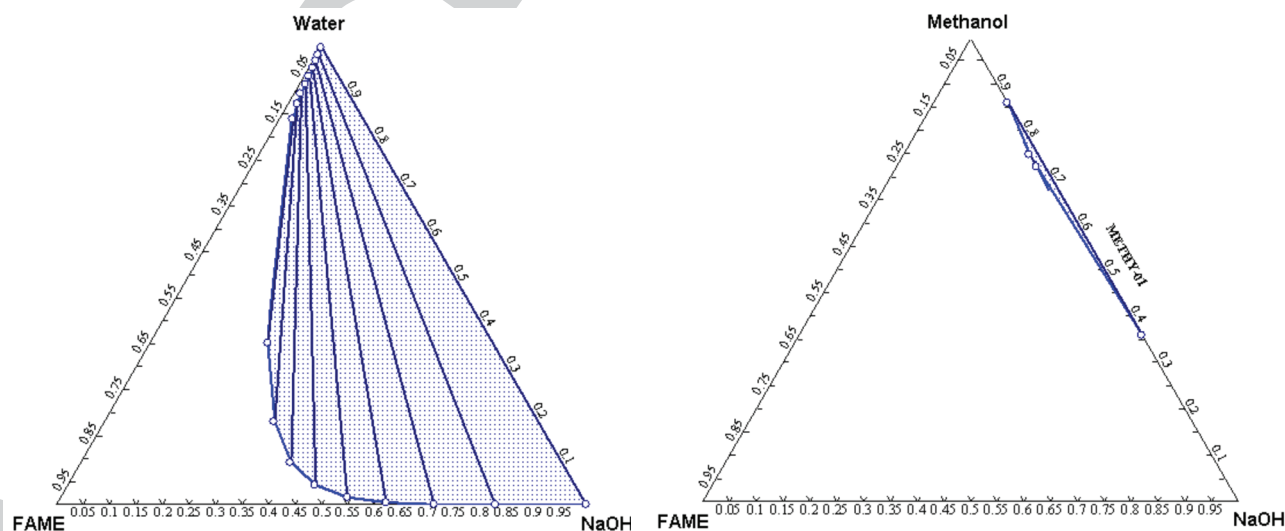

Figure 5. The triangular diagram for the system (a) FAME-water-NaOH and (b) FAME-methanol-NaOH.

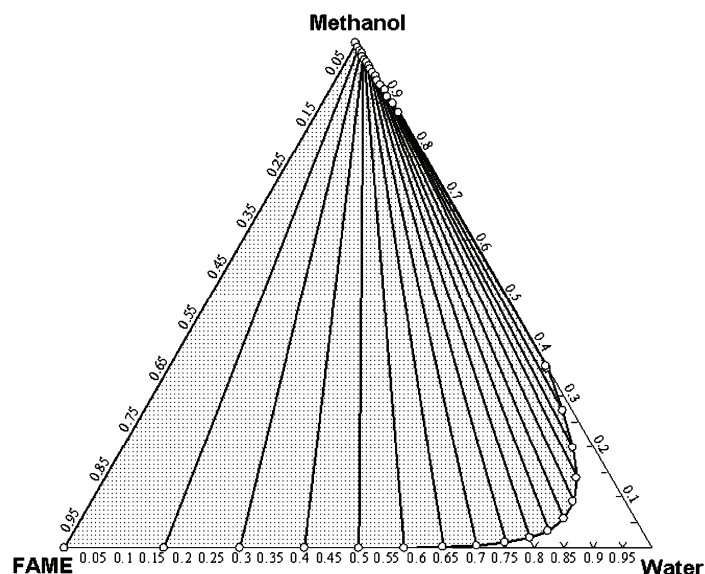

Figure 6. The triangular diagram for the system FAME-methanol-water.

As it can be seen from the data shown in Table 6, the optimized washing procedure requires almost the same process units (less for 1) which requires the same capital investment. Regarding the water consumption in both suggested processes, the classic one required 210 kg/h of water and the optimized one only 55 kg/h (50 kg/h for FAME washing and 5 kg/h for mineral acid dissolving and glycerol layer neutralisation). Accordingly, only 5 kg/h should be evaporated instead of 210 kg/h in the classic process. However, the total energy consumption (calculated for the classical industrial process, 2326 kW [16]) could be drastically reduced; about 50% reduction of the energy consumption could be realized compared to the energy consumption for the biodiesel production based on a simple procedure of washing today widely applied in industry.

## CONCLUSION

The main goal of this analysis was to minimize the water usage in the washing-neutralization step

during the biodiesel production. Such solution would make the process of biodiesel synthesis more economical taking into account a decrease of energy consumed for evaporation of water during the final product purification as well as a more acceptable procedure related to the impact on the environment (minimal waste water release). The simulation of the process was performed using ASPEN plus software supported by ELCANTREL and UNIQUAC procedure of required properties calculation.

The results of the performed analysis and its optimization suggested that such neutralization and applied optimized washing procedure of methyl ester layer gives the best solution.

The main conclusion from this study arise from the fact that the first step after removal of the excess of methanol must be the separation of glycerol and methyl esters layers and then a washing procedure with a small amount of added water could be applied using only glycerol layer.

The significant amount of water for washing and ortho-phosphoric acid will be decreased if a simple

Table 6. Number of units required for different washing procedures and calculated energy consumption

Equipment	Simple (classical) washing procedure (energy consumption)	Optimized washing procedure (energy consumption)
Reactor	1 (0 kW) <sup>a</sup>	1 (0 kW) <sup>1</sup>
Heat Exchangers	1 (0 kW)	0
Gravity separator	2 (0 kW)	1 (0 kW)
Evaporator	1 (1039 kW)	1 (45 kW)
Washing column	0	1 (0 kW)
Total	5 (1039 kW)	4 (45 kW)

<sup>a</sup>Without energy necessary for mixing in reactor



washing procedure is replaced by the optimized one; the 72 mass% of water and 71 mass% of mineral acid compared to the values calculated on the basis of the simple washing procedure giving at the same time desired purity of the final products (FAME or biodiesel and glycerol).

### Acknowledgements

The financial support of the Ministry of Science and Technological Development of the Republic of Serbia, project No. TR19062 and project No. ON 142073, is gratefully acknowledged.

### REFERENCES

- [1] B. Freedman, R.O. Butterfield, E. H. Pryde, *J. Am. Oil Soc. Chem.* **63** (1986) 1375-1380
- [2] H. Nouredini, D. Zhu, *J. Am. Oil Soc. Chem.* **74** (1997) 1457-1463
- [3] G. Vicente, M. Martinez, J. Aracil, *Biores. Technol.* **98** (2007) 1724-1733
- [4] G. Vicente, M. Martinez, J. Aracil, *Biores. Technol.* **98** (2007) 1754-1761
- [5] D. Darnoko, M. Cheryan, *J. Am. Oil Soc. Chem.* **77** (2000) 1263-1267
- [6] F. Karaosmanoglu, K. B. Cigizoglu, M. Tuter, S. Ertekin, *IEnergy Fuels* **10** (1996) 890-895
- [7] T. Krawczyk, *Biodiesel Inform.* **7** (1996) 801-822
- [8] Y. Zhang, M. A. Dube, D. D. McLean, M. Kates, *Biores. Technol.* **89** (2003) 1-16
- [9] M. J. Haas, A. J. McAloon, W. C. Yee, T. A. Foglia, *Biores. Technol.* **97** (2006) 671-678
- [10] K. Kapilakarn, Ampol Peugtong, *Int. Energy J.* **8** (2007) 1-6
- [11] J.M. Marchetti, A.F. Errazu, *Energy Conv. Manag.* **49** (2008) 2160-2164
- [12] M. Berrios, R.L. Skelton, *Chem. Eng. J.* **144** (2008) 459-465
- [13] A. Z. Abdullah, N. Razali, H. Mootabadi, B. Salamatinia, *Environ. Res. Lett.* **2** (2007) 1-6
- [14] L. C. Meher, D. Vidya Sagar, S. N. Naik, *Renew. Sust. Energy Rev.* **3** (2004) 1-21
- [15] AOCS, *Official and Tentative Methods*, American Oil Chemists' Society, Chicago (1980)
- [16] S. Glišić, D. Skala, J. Supercrit. Fluids **49** (2009) 293-301
- [17] AspenTech, Aspen physical property system: physical property methods and models 11.1.aspentech, 2001, 405-435 ([www.aspentech.com](http://www.aspentech.com))
- [18] C.-C. Chen, H.I. Britt, J.F. Boston, L.B. Evans, *AIChE J.* **28** (1982) 588-596
- [19] C.-C. Chen, L.B. Evans, *AIChE J.* **32** (1986) 444-459
- [20] D.S. Abrams, J.M. Prausnitz, *AIChE J.* **21** (1975) 116-128
- [21] A. Bondi, *Physical Properties of Molecular Crystals, Liquids and Gases*, Wiley, New York, 1960
- [22] J. Simonetty, D. Yee, D. Tassios, *Process Des. Dev.* **21** (1982) 174-179.

### APPENDIX I ELECTROLYTE NRTL MODEL - ELCANTREL

The Electrolyte Non-Random Two Liquid (NRTL) model is a versatile model for the calculation of activity coefficients. Using binary and pair parameters, the model can represent aqueous electrolyte systems as well as mixed solvent electrolyte systems over the entire range of electrolyte concentrations. This model can calculate activity coefficients for ionic species and molecular species in aqueous electrolyte systems as well as in mixed solvent electrolyte systems [17].

The electrolyte NRTL model uses the infinite dilution aqueous solution as the reference state for ions. It adopts the Born equation to account for the transformation of the reference state of ions from the infinite dilution mixed solvent solution to the infinite dilution aqueous solution. Water must be present in the electrolyte system in order to compute the transformation of the reference state of ions. Thus, it is necessary to introduce a trace amount of water to use the model for nonaqueous electrolyte systems [17-19].

The model is based on two fundamental assumptions [17]:

- The like-ion repulsion assumption: states that the local composition of cations around cations is zero (and likewise for anions around anions). This is based on the assumption that the repulsive forces between ions of similar charge are extremely large. This assumption may be justified on the basis that repulsive forces between ions of the same sign are very strong for neighbouring species.

- The local electro-neutrality assumption states that the distribution of cations and anions around a central molecular species is such that the net local ionic charge is zero. Local electro neutrality has been observed for interstitial molecules in salt crystals.

The model adjustable parameters include [17-19]:

- pure component dielectric constant coefficient of nonaqueous solvents,
- Born radius of ionic species and
- NRTL interaction parameters for molecule-molecule, molecule-electrolyte, and electrolyte-electrolyte pairs:

$$\ln \gamma_i = \frac{C_i}{S_i} + \sum_{j=1}^c x_j G_{ij} \left( \tau_{ij} - \frac{C_j}{S_j} \right) / S_i$$

$$\tau_{ij} = (g_{ij} - g_{ji}) / RT$$

$$G_{ij} = \exp(-\alpha_{ij}\tau_{ij})$$

$$S_i = \sum_{j=1}^c x_j G_{ij}$$

$$C_i = \sum_{j=1}^c x_j G_{ij} \tau_{ij}$$

Dielectric constant coefficient of pure solvent B could be calculated from the following equation:

$$\varepsilon_B(T) = A_B + B_B \left( \frac{1}{T} - \frac{1}{C_B} \right)$$

Binary interaction parameters could be calculated for:

molecule-molecule pairs,

$$\tau_{BB'} = A_{BB'} + \frac{B_{BB'}}{T} + F_{BB'} \ln(T) + G_{BB'} T$$

molecule-electrolyte pairs,

$$\tau_{ca,B} = C_{ca,B} + \frac{D_{ca,B}}{T} + E_{ca,B} \left[ \frac{(T^{ref} - T)}{T} + \ln \left( \frac{T}{T^{ref}} \right) \right]$$

$$\tau_{B,ca} = C_{B,ca} + \frac{D_{B,ca}}{T} + E_{B,ca} \left[ \frac{(T^{ref} - T)}{T} + \ln \left( \frac{T}{T^{ref}} \right) \right]$$

and electrolyte-electrolyte pairs,

$$\tau_{c'a,c''a} = C_{c'a,c''a} + \frac{D_{c'a,c''a}}{T} + E_{c'a,c''a} \left[ \frac{(T^{ref} - T)}{T} + \ln \left( \frac{T}{T^{ref}} \right) \right]$$

$$\tau_{ca',ca''} = C_{ca',ca''} + \frac{D_{ca',ca''}}{T} + E_{ca',ca''} \left[ \frac{(T^{ref} - T)}{T} + \ln \left( \frac{T}{T^{ref}} \right) \right]$$

where  $T^{ref}$  is referent temperature (298.15 K was used in this study).

## APPENDIX II THE UNIQUAC MODEL

UNIQUAC (short for UNiversal QUAsi Chemical) is an activity coefficient model in which the activity coefficients,  $\gamma$ , of the components in a chemical mixture can be related through their molar fraction,  $x_i$  [20]. The UNIQUAC model calculates liquid activity coefficients and it is recommended for highly non-ideal chemical systems, and can be used for VLE and LLE applications [21,22].

UNIQUAC requires two basic underlying parameters [20]:

- relative surface  $\theta_i$  and volume  $\Phi_i$  fractions are chemical constants, which must be known for all chemicals;

-An empirical parameter between components that describes the intermolecular behaviour. This parameter must be known for all binary pairs in the mixture. The empirical parameters are derived from experimental activity coefficients, or from phase diagrams, from which the activity coefficients themselves can be calculated.

For the multi-component liquid system at defined temperature and pressure, the total Gibbs energy (per one mol of mixture) could be defined as Gibbs energy of mixing,  $g^M$ :

$$\frac{g^M}{RT} = \sum_{i=1}^n x_i \ln(x_i) + \frac{g^E}{RT}$$

where is  $x_i$  the mol fraction of component i,  $n$  is number of components in the mixture and  $g^E$  is the excess Gibbs energy expressed as [20-22]:

$$\frac{g^E}{RT} = \frac{g_{comb}}{RT} + \frac{g_{res}}{RT}$$

$$\frac{g_{comb}}{RT} = \sum_{i=1}^n x_i \ln \frac{\Phi_i}{x_i} + 5 \sum_{i=1}^n q_i x_i \ln \frac{\theta_i}{\Phi_i}$$

$$\frac{g_{res}}{RT} = - \sum_{i=1}^n q_i x_i \ln \sum_{j=1}^n \theta_j \tau_{ij}$$

$$\Phi_i = \frac{r_i x_i}{\sum_{j=1}^n r_j x_j}$$

$$\theta_i = \frac{q_i x_i}{\sum_{j=1}^n q_j x_j}$$

$$r_{i,j} = \exp\left(\frac{-\Delta u_{i,j}}{RT}\right)$$

The binary interaction parameters,  $-\Delta u_{ij}$ , could be calculated from the experimental data.